

# 1 Tonne Hi-Tip Hydrostatic

MACH201

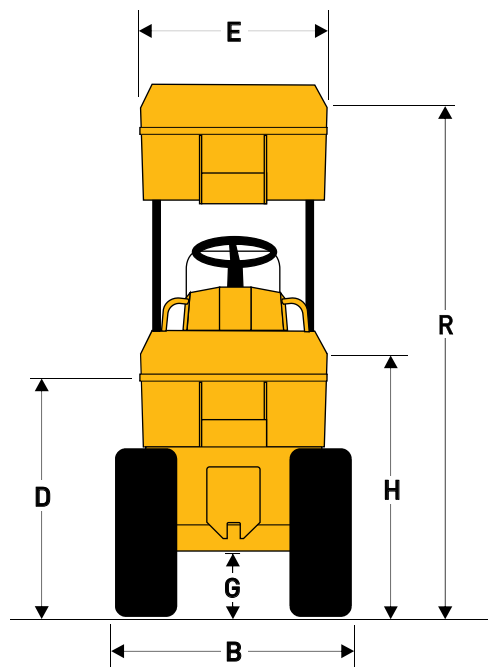
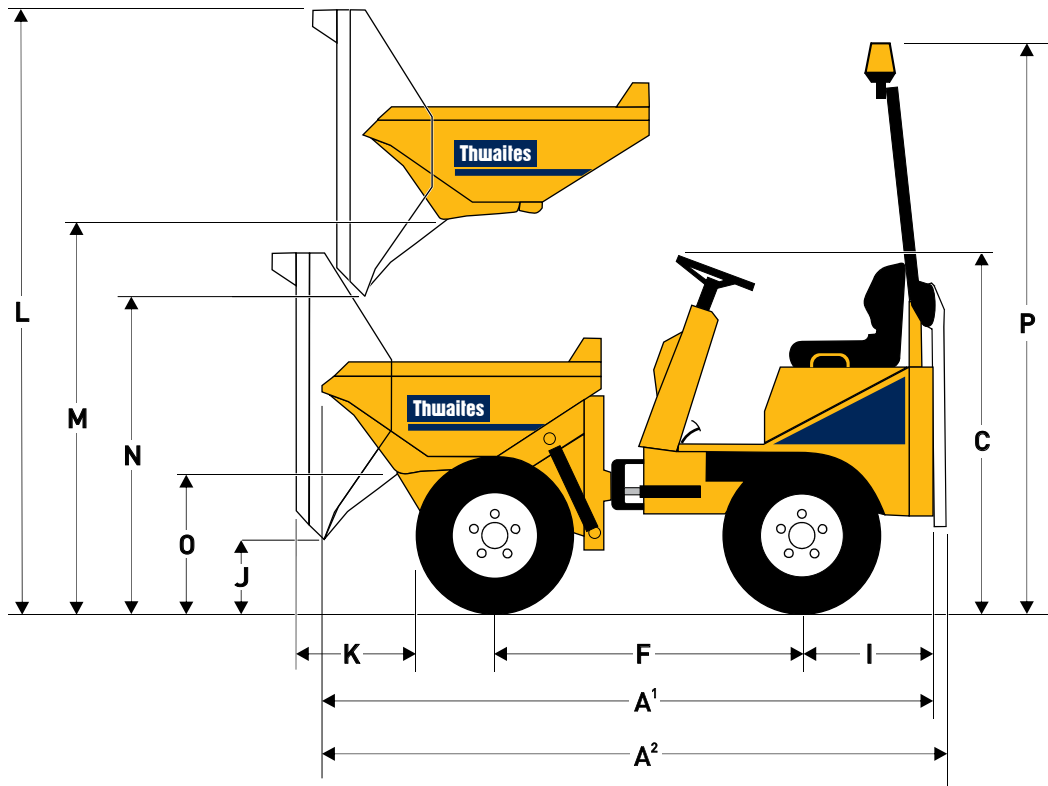

## Dimensions (mm)

A <sup>1</sup>	3032
A <sup>2</sup>	3192
B	1115 (982*)
C	1773
D	1155
E	982
F	1500
G	274
H	1262
I	654
J	346
K	505
L	3005
M	1913
N	1573
O	720
P	2860
R	2370

\*with optional narrow wheels

# 1 Tonne Hi-Tip Hydrostatic

MACH201

<b>Capacities</b>	Max safe load	1000 kg
	Heaped	500 litres
	Struck	400 litres
	Water	280 litres

## Engine

Yanmar 3TNV76, 15.9 kW/21.4 bhp (nett) @ 2800 rpm, 3-cylinder water-cooled diesel. Max torque 66.4 Nm (49 lb f ft). Electric starting, hour meter, battery isolator switch and heavyduty cyclonic air cleaner positioned within the lockable engine compartment.

## Noise Levels

Operator's ear 84 LpA, airborne sound power level 101 LwA (to 2000/14/EC).

<b>Speeds</b>	Forward / reverse	0-12 km/h
---------------	-------------------	-----------

<b>Tyres</b>	<b>Standard</b>	<b>Optional</b>
	10.0/75 x 15.3	7.00 x 12
	8 Ply	6 Ply
	Track grip tread	Track grip tread

## Brakes and Axles

Automatic failsafe braking system incorporated into rear drive motors.

## Chassis

Front and rear chassis constructed from folded steel plate, with centre-point articulation and oscillation for optimum stability and traction.

## Drive System

Hydrostatic with variable displacement pump feeding four wheel motors, incorporating "Twin-Lock" system to maximise traction.

## Skip

Hydraulically operated, 3 mm base, 4 mm sides steel plate. Mouth reinforced with box sections giving greater strength to minimise damage, no material traps. Raise and tip control operated by twin control levers.

## Seating & Controls

Column-mounted forward/reverse lever with foot pedal speed control. Adjustable suspension seat, accessible from both sides. Audible warning device at key start 'on' position. Super-bright warning lights for all critical functions. Electric horn.

## Service Access

Lockable three-sided cover provides easy access from ground level to engine service points.

## Electrics

Wiring harness contained within conduits and all electrical components water resistant to IP65/67 standards.

## Steering & Hydraulics

Hydraulic power steering. Return line filtration for all services and large capacity suction strainer in the tank to give full circuit protection. Hydraulic test point fitted as standard.

<b>Tank Capacities</b>	Fuel	21 litres
	Hydraulic	20 litres

<b>Shipping Cube</b>	6.3 m <sup>3</sup> (with folded ROPS)
----------------------	---------------------------------------

<b>Unladen Weight</b>	1295 kg
-----------------------	---------

<b>Clearance Diameter</b>	5.45 m
---------------------------	--------

## ROPS/Beacon

A folding ROPS bar and beacon are fitted as standard.

## Optional EXtras

Full road lighting equipment. Reverse alarm. UK road equipment. Towing bracket. Sand tyres and narrow tyres.

Distributor

# Thwaites

Thwaites Ltd. Leamington Spa, Warwickshire CV32 7NQ, England  
 Tel +44 (0)1926 422471 Fax +44 (0)1926 337155  
 www.thwaitesdumpers.co.uk



We reserve the right to change all specifications without prior notice.  
 Printed in England 08/2017